

OptiCal

Humidity calibrator



The OptiCal is a bench-top, fully self-contained humidity/temperature calibrator. The system comprises a humidity and temperature controlled chamber that can house up to five or more humidity sensors, depending on their physical dimensions. The humidity and temperature within the chamber are closed-loop controlled and continuously monitored by a precision chilled mirror reference hygrometer. The Opti-Cal works by time proportioning the flows of dry and saturated air according to the pre-selected relative humidity value. The chamber temperature is controlled by a four-zone Peltier heat pump arrangement for maximum stability and minimum temperature gradient. The saturator assembly can be filled easily with distilled water reservoir at the front of the unit and the easily accessible desiccator can be re-charged by heating when required. No other maintenance is necessary. The only external service required is a single phase power supply.

Highlights

- Precision relative humidity and temperature calibrator
- Generate 10 to 90% RH over 10 to 50°C temperature
- Integral cooled mirror reference hygrometer
- Humidity and temperature profile generation for unattended verification of sensors
- Transportable calibrator enables on-site calibrations

Technical Specifications

Reference Hygrometer

Type Optidew cooled mirror dew-point transmitter

Humidity

Generator range 10–90% RH
Accuracy $\leq \pm 1\%$ RH (10–70% RH)
 $\leq \pm 1.5\%$ RH (70–90% RH)
Stability $\pm 0.2\%$ RH (20–80% RH)

Temperature

Generator range +10°C to +50°C
 (lowest T set point = 10°C below ambient)
Accuracy $\pm 0.1^\circ\text{C}$
Stability $\pm 0.1^\circ\text{C}$

Chamber

Ramp rate from +20 to +40°C 1.5°C/minute
+40 to +20°C 0.7°C/minute
Control element Removable relative humidity sensor

General

Probe ports up to 5 – sensor body diameters 5–24mm accommodated by port adapters
Chamber volume 2000 cm³
Chamber dimensions 105 x 105 x 160mm (w x h x d)
Instrument dimensions 520 x 290 x 420mm (w x h x d)
Set point resolution 0.1 for humidity and temperature
Displays High definition 2 lines alpha numeric
Measurement units °C, °Cdp, % RH
 g/kg, g/m³, (t-t_d), a_w
Outputs
 Analogue Two channels 4-20mA or 0-20 mA
 Digital RS-232 (RS-485 optional)
 Alarm Volt free contact, 2A @ 30VDC
Supply 85–264VAC, 47–63Hz, 150VA
Weight 20kg



Logging and profiling software

Accessories and spare parts

Door kit with 1x ø19.0mm port	A-000260
Door kit with 5 ports. 5x ø19.0 mm adapters, 4x ø12.0-13.5-15-18.5-24 mm adapters and blind stops. Adapter tool included	A-000264
Door with clear window – no ports	A-000266
Plastic port adapter & blind stop (for customer modification)	A-000290
ø12.0mm port adapter. Plastic adapter (M30x1) & blind stop	A-000291
ø13.5mm port adapter. Plastic adapter (M30x1) & blind stop	A-000292
ø14.0mm port adapter. Plastic adapter (M30x1) & blind stop	A-000293
ø15.0mm port adapter. Plastic adapter (M30x1) & blind stop	A-000294
ø18.5mm port adapter. Plastic adapter (M30x1) & blind stop	A-000295
ø19.0mm port adapter. Plastic adapter (M30x1) & blind stop	A-000296
ø24.0mm port adapter. Plastic adapter (M30x1) & blind stop	A-000297
ø25.0mm port adapter. Plastic adapter (M30x1) & blind stop	A-000298
Tool for M30x1 Aluminium adapters	A-000265
Control sensor	HT-961
Transport case	OCAL-TC

Ordering codes

Basic model:	OptiCal
Precision Humidity Calibration system with temperature control. Includes 5 port door and integrated chilled mirror reference hygrometer with 3 point NIST/UKAS RH calibration	

Dimensions

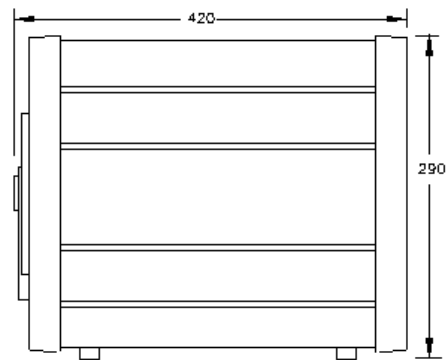
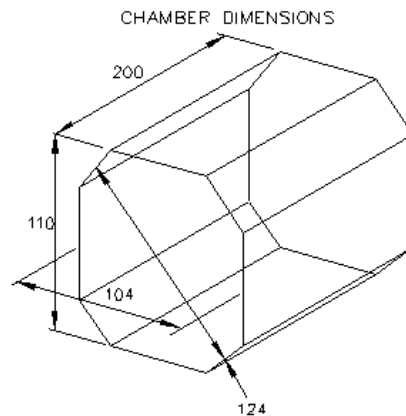
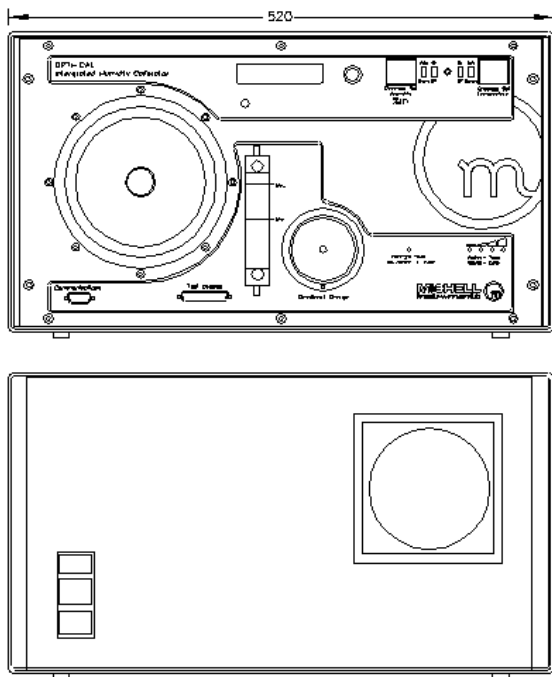

Please note: Michell Instruments adopts a continuous development programme which sometimes necessitates specification changes without notice. Please contact us for latest version. Ref: OptiCal_0309