

DryCheck

Self-Contained Dew Point Instrument

A simple and efficient, self-contained dew point hygrometer, with filtration and flow control, for measurement of dew point or moisture content



Features

- Integrated instrument and sampling system
- Simple installation
- Wide measurement range
- Dew point or moisture content
- Analogue output, display and dual alarms
- IP65 enclosure

Applications

- Compressed air dryers
- Plastic moulding
- Ozone generators
- Medical gases
- Pneumatics
- Breathing air
- Welding gases
- ... and many more

Background

The DryCheck dew point instrument was designed by Michell Instruments as a response to demands from customers for an accurate, stable but economic instrument, with simple sampling system, which could be easily installed for use in a number of dew point measurement applications.

In medical gas, and many other, applications a cost efficient and reliable hygrometer, which is simple to install, is vital to ensure that dew point measurement can be made for each dryer.

Fast Response and Accurate Measurement

The DryCheck utilises the Michell Instruments Easidew Online to measure dew point in the range -100 to $+20^{\circ}\text{C}$ dew point, or moisture content in the range 0-3000 ppm. This well proven instrument has at its heart, Michell's advanced Ceramic Moisture Sensor, providing accurate and stable measurement. The calibration data for each sensor is stored within the transmitter's flash memory. This allows Michell Instruments to offer the unique sensor exchange scheme, keeping calibration costs and downtime to an absolute minimum.

Simple Installation

All components are housed in a rugged IP65 rated polycarbonate case. This can easily be wall mounted at a convenient point close to the gas sample.

A clear cover protects the display and the sample flowmeter. Gas connection (gas in and gas out) is provided using "quick connect" push-fittings suitable for use with 6 mm OD Teflon tubing. Mains power input, and connection to the 4-20 mA analogue output, and the two user programmable voltage free relay contacts are all easily accessible behind the lower panel.

www.michell.com

DryCheck

Self-Contained Dew Point Instrument

Dew point or moisture content

Analogue output, display and two alarms

IP65 enclosure



Related Products



Easidew TX

Easidew Online

Integral Sampling System

The DryCheck sampling system includes a 0.3 micron particulate filter element, a monolithic sampling block to house the Easidew Transmitter, and a valve and flowmeter for setting the sample flow. The filter element is easily replaceable to ensure that the sensor is protected. All components are rated to 10 Barg and the DryCheck can be configured for measurement of dew point at either system, or atmospheric pressure.

Display and Outputs

The DryCheck features an extremely clear 20 mm red LED display, which can be programmed to display dew point, in °C or °F and moisture content in ppm_v. The instrument also provides a 4-20 mA output and 2 off alarm relays. All these features are easily configurable by the user via the front panel of the display, making DryCheck one of the most versatile instruments on the market.

Integrated instrument and sampling system

Flow meter

Simple gas connections

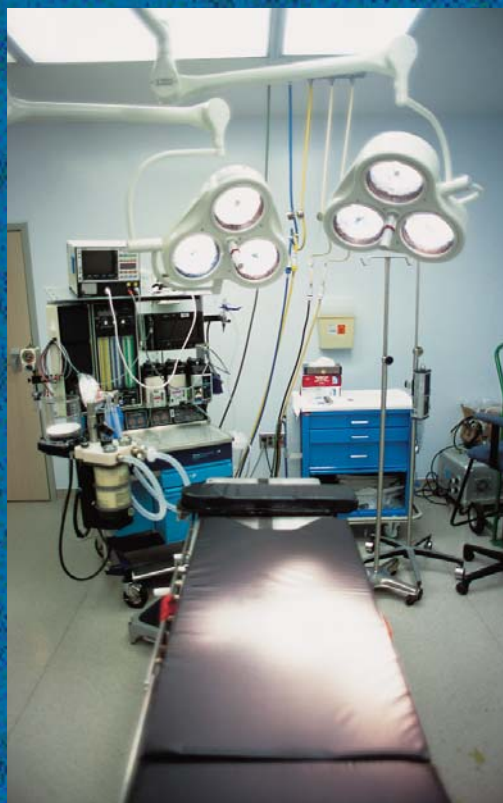

Cermet II

Easidew Sampler

Please note: Michell Instruments adopts a continuous development program which sometimes necessitates specification changes without notice.



DryCheck

Self-Contained Dew Point Instrument

Technical Specifications

Measurement range	-100 to +20°C dew point 3000 ppm _v (ppm _v output or non-standard dew point range must be specified at time of order)
Accuracy	±2°C dew point
Operating temperature	-5 to +50°C
Storage temperature	-40 to +75°C
Output	4-20 mA maximum load resistance 500 Ω
Alarm	2 volt free contacts 3 A @ 240 V
User interface	Front panel configuration of alarm points
Display	20 mm red LED
Power supply	85 to 265 VAC, 50/60 Hz
Ingress protection	IP65
Mains cable	2 m cable supplied
Gas pressure	10 Barg max (high pressure option available)
Sample flow rate	1-5 Litres / min
Filtration	99.5 % removal of 0.3 micron
Gas connection	Quick Connect fittings for 6 mm OD Teflon pipe

Technical Specifications
For full specification please see the Easidew Transmitter and Easidew Online datasheets

Dimensions

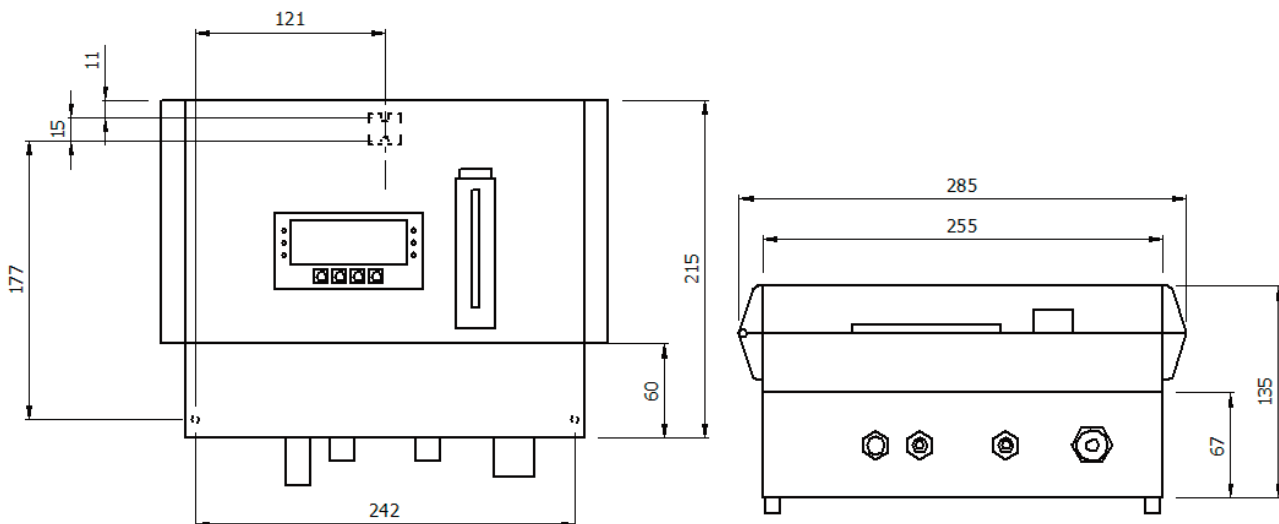

Michell Instruments Ltd

48 Lancaster Way Business Park
Ely, Cambridgeshire
CB6 3NW, United Kingdom

Tel: +44 (0) 1353 658 000

Fax: +44 (0) 1353 658 199

Email: info@michell.co.uk

Web: www.michell.com



Please note: The accuracy stated represents the typical variation between the instruments under test and a calibrated and corrected reference.

Please contact us for the latest version: DryCheck: Ref: DC-0308

DryCheck