

# ECO PHYSICS CLD 822 S r

## Application examples



Burners
Energy supply
Certification and calibration authorities
DeNOx plants
Cement producers
Refineries
Tobacco industry
Research and development

**The solution for simultaneously measured NO and NO<sub>x</sub> has got a name: CLD 822 S r. This analyzer even offers the possibility to measure two separate sources – a unique option!**



### Two instead of one.

The CLD 822 S r nitrogen oxide analyzer is optimized for its use in systems which include gas sampling equipment to measure different samples in parallel.

The outstanding feature is the concept of two parallel reaction chambers. They guarantee simultaneous measurement of NO and NO<sub>x</sub> in order to generate the precise value of NO<sub>2</sub>.

The analyzer is capable of coping with two separate measurement tasks. This may include the task of comparing the values at the inlet and the outlet of a process or the direct comparison of two independent samples. The analyzer simply requires a dual inlet feature option (d) and one additional converter.

### A fascinating technology.

The analyzer is not only a state-of-the-art product in terms of precision and reliability. Its technological base also sets the trend for others. Naturally occurring pressure variations in the sample flow are balanced out by means of an electronic and mechanical bypass system. This module option (r) is not required in systems with an external sample pressure regulation.



*All external connections are hidden but easily accessible from the rear.*

Many options can be integrated without any problem to satisfy the need for non-standardized applications. The advantage of compact design: the CLD 822 S r includes everything inside the case – even the vacuum pump and the ozone scrubber.



### User friendliness is a top priority.

The analyzer can be operated by means of the integrated keypad or remotely from a personal computer. The clear layout of the menu structure guides the user and enables him to take advantage of all analyzer functions with simple commands. Integrating the analyzer in larger systems is possible by including runners in the standard chassis design.

- Four freely selectable measurement ranges [with option (d) two per channel]

- Choice between several types and numbers of converters from 0 to 2 according to the application

- Error message coded and in full text

- Rapid system integration

- Virtually maintenance-free even in continuous operation.



*Two independent measuring ranges with option (d).*

# CLD 822 S r

## Specifications

<b>Measuring ranges</b>	four freely selectable ranges from 5–5000 ppm, with option d two per channel	<b>Supply voltage</b>	100 – 230 V / 50 – 60 Hz
<b>Min. detectable concentration</b>	0.25 ppm*	<b>Interface</b>	RS 232 (standard)
<b>Noise at zero point (1 <math>\sigma</math>)</b>	0.125 ppm*	<b>Analog output</b>	4–20 mA into 500 $\Omega$ max.; 0–1 V; 0–10 V
<b>Lagtime</b>	<1 sec	<b>Dimensions</b>	height: 133 mm (5 1/4 ") width: 450 mm (19 ") with moulding: 495 mm depth: 545 mm
<b>Rise time (0–90%)</b>	<1 sec	<b>Weight</b>	26 kg
<b>Temperature range</b>	5–40 °C	<b>Delivery includes</b>	CLD 822 S r analyzer, power cable, RS 232 cable, analog signal cable, manual
<b>Humidity tolerance</b>	5–95% rel. h (non-condensing, ambient air and sample gas)	<b>Standard</b>	CLD 822 S r steel converter and electro- mechanical pressure regulation
<b>Quenching (with gas cooler)</b>	for H <sub>2</sub> O: <1.5% of meas. value for CO <sub>2</sub> : <0.3%/vol.-% CO <sub>2</sub>	<b>Options</b>	M metal converter d dual sample gas inlet MM d dual channel NO <sub>x</sub> /NO <sub>x</sub>
<b>Sample flow rate</b>	1.2 l/min (0.1 l/min without option r)	<i>* depending on filter setting</i>	
<b>Input pressure</b>	600–1200 mbar abs. (without option r to be externally stabilized within $\pm 3$ mbar)	<b>ECO PHYSICS reserves the right to change these specifications without notice.</b>	
<b>Dry air use for O<sub>3</sub> generator</b>	internally generated (no external supply gas required)		
<b>Power required</b>	400 VA (incl. membrane pump and ozone scrubber)		

## Flow diagram

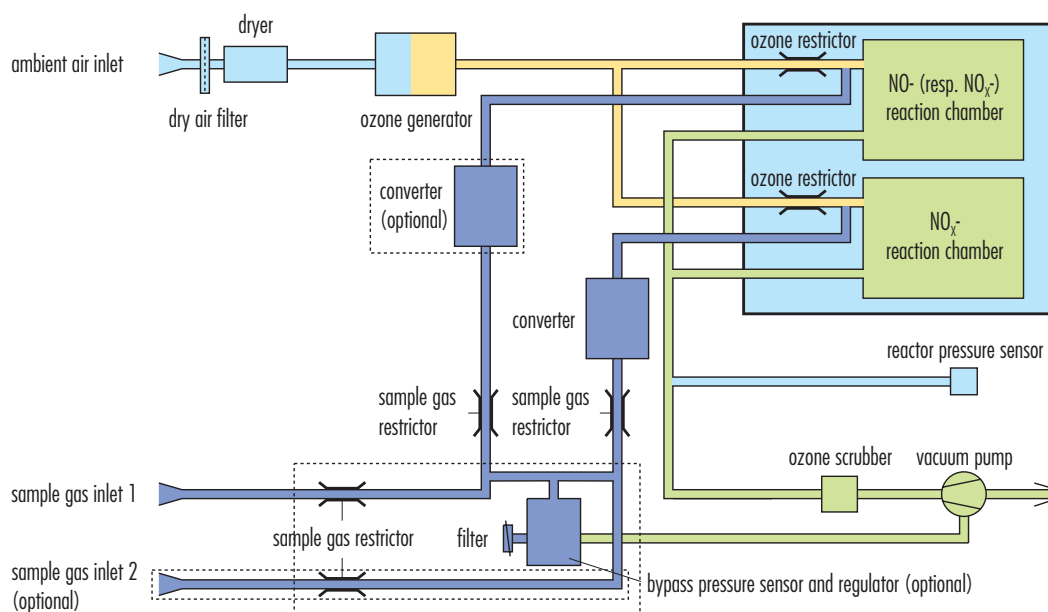

ECO PHYSICS

ECO PHYSICS AG · POB 282 · CH-8635 DUERNEN · TEL. +41 55 220 22 22 · FAX +41 55 220 22 55 · E-MAIL INFO@ECOPHYSICS.COM  
WWW.ECOPHYSICS.COM